

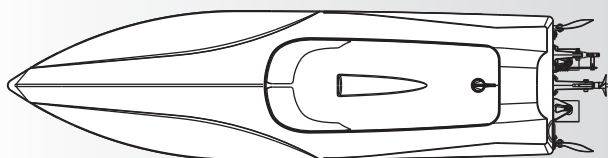

BRUSHLESS MOTOR BOAT

ASSEMBLY AND OPERATION MANUAL

Specifications:



Alpha Race Boat Model No: 8901

Hull Length.....	950mm
Total Length.....	1060mm
Beam.....	260mm
Speed.....	80+KPH
Hull Material: Plastic with water transfer printing stickers and painting finished	

Universal Assembly:

Motot.....	Water cooled Powerful Out-runner brushless Motor(Included)
Radio System.....	2.4G 2CH Digital Proportional Transmitter(Included)
Speed Control.....	Water Cooled 90A Brushless ESC w/BEC (Included)
Servo.....	Powerful steering 9kgs high torque servo (Included)
Propeller.....	Two pcs of two blade metal propeller (Included)
Drive System.....	5mm Flex Cable Direct Drive
Battery.....	Two packs of 11.1V 5000mAh 40C LiPo Pack(Not Included)
OR	
Battery.....	Two packs of 7.4V 5000mAh 40C LiPo Pack(Not Included)
Charger.....	2S/3S Balance chager and adapter(Not Included)

IMPORTANT: THIS MODEL ARE CAPABLE OF OVER 80 KPH, PERSONAL INJURY OR PROPERTY DAMAGE MAY RESULT FROM MISUSE OF THESE PRODUCTS, TAKE CARE AND ENJOY OUR MODEL RESPONSIBLY.

INSTRUCTION MANUAL **THIS MODEL IS NOT A TOY!**

ALPHA ARTR BRUSHLESS EP RACING BOAT

THESE INSTRUCTIONS SHOULD BE READ BY A SUPERVISING ADULT

CONTENTS OF SET

1. Transmitter
2. Two pcs of metal propeller
3. Gold connectors w/Heatshrink-Fit to LiPo batteries if not already fitted
4. Rubber ballon & cable strap (For receiver)
5. Turn fins
6. Allen key (3pcs)
7. Boat stand with rubber cushion
8. Aluminium rudder & support
9. Alpha race boat

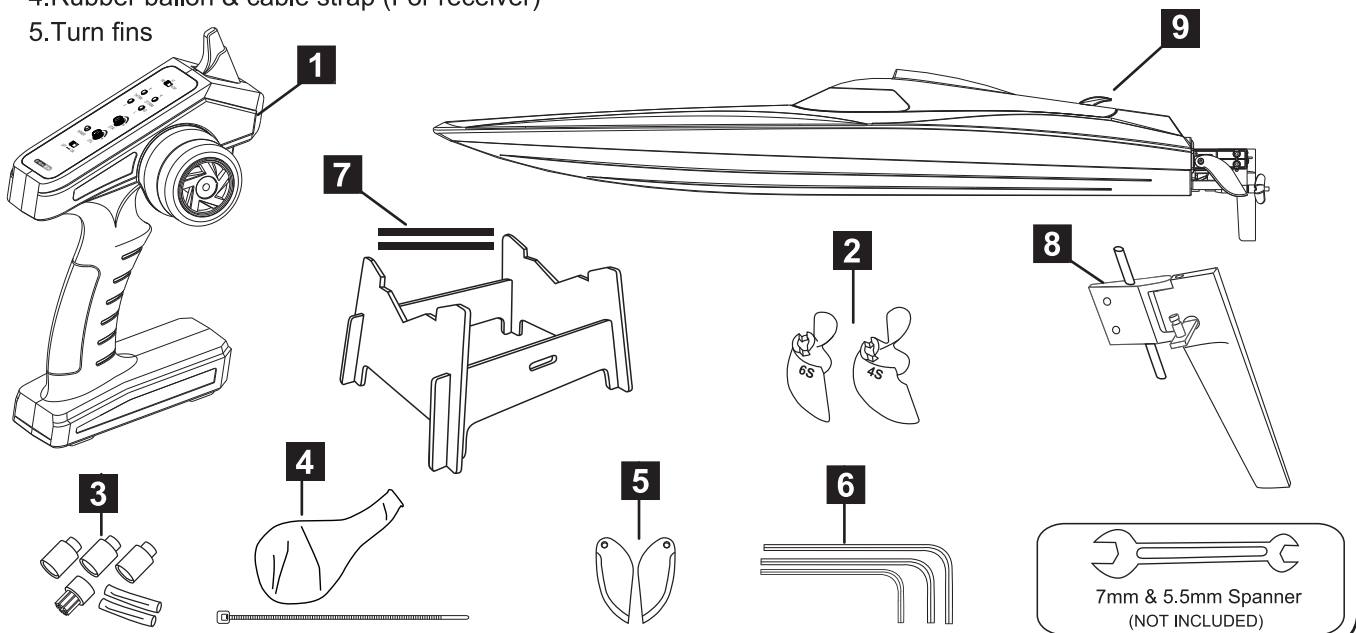

REQUIRED FOR (NOT INCLUDED)

- 1) 2packs of 7.4V 5000mAh(or greater) 40C(or greater) LiPo or
- 2) 2packs of 11.1V 5000mAh(or greater) 40C(or greater) LiPo
- 3) LiPo battery charger
- 4) 5.5 and 7mm spanner
- 5) 4pcs AA alkaline batteries (for transmitter)

Note: Li-Po batteries should have Gold connectors fitted. If not supplied with Li-Po batteries, solder included Gold connectors to Li-Po battery wires noting correct polarity (+/-).

PROPELLER

Two metal propeller included in the kit bag

P1.4 x 60mm  + 4S 5000mAh(or greater) 40C(or greater) LiPo = 60km/h

P1.4 x 56mm  + 6S 5000mAh(or greater) 40C(or greater) LiPo = 80km/h

IMPORTANT NOTE:

Please don't misused the propeller to race inappropriate batteries cells, otherwise, This action will lead to motor and ESC overloaded.

IMPORTANT

Before using this Alpha model and its radio control system, and to ensure the safety of yourself and others, it is very important that you read these instructions thoroughly and understand them.

Alpha model is capable of speeds in excess of 80+km/h! Care should be taken to avoid the possibility of injury and/or property damage.

Alpha model is designed for use in fresh water only. They are not designed for use in salt water!

Alpha model is not intended for persons under 14 years of age, unless closely supervised by an adult.

ASSEMBLING THE BOAT STAND

Assemble the included boat stand by slotting the pieces together as shown. Apply cyanoacrylate glue or 2-part epoxy to secure the joints and allow the glue to completely set before placing your Alpha boat on it.

Apply the supplied rubber cushion on the boat stand to prevent the scratch to the hull bottom.

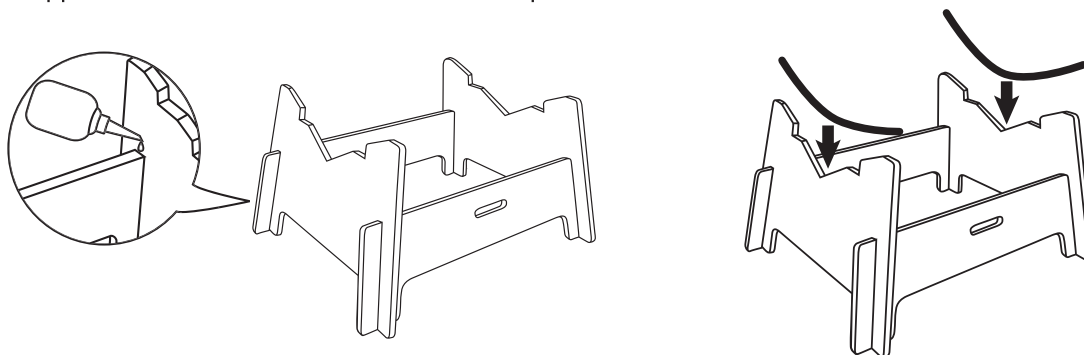

INSTALLING THE RUDDER AND PROPELLER AND TURN FINS

- 1) Slide the rudder assembly into its mount and secure with the cap screws and nuts provided using the included 3.0mm Allen key and a 5.5/7mm spanner. See 'ADJUSTING THE REAR SHAFT STRUT' section overleaf for details of position.
- 2) Slide the rudder connecting rod through the mount in the rudder arm and secure it using the 2.5mm Allen Key.
- 3) Take the silicone cooling tube that exits the right rear side of the hull and push it onto the water inlet nipple on top of the rudder.
- 4) fit a propeller to the propeller shaft and secure with the intended nylon nut. Do not overtighten as the nylon insert will prevent the nut from accidentally working loose!
- 5) Install adjustable turn fins on the turn fins stand using 3.0mm allen key and 5.5/7mm spanner. The optimum angle of adjustment is 45 degrees to the hull.



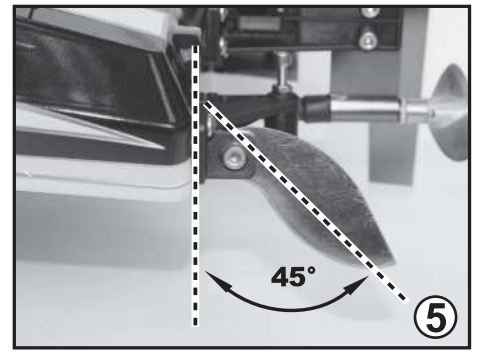
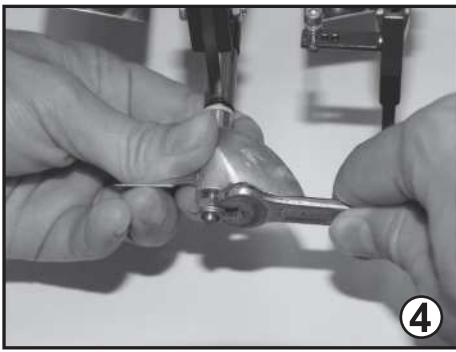

ADJUSTING THE REAR SHAFT STRUT

The position of the rear shaft strut to the hull will have an effect on the way your boat performs.

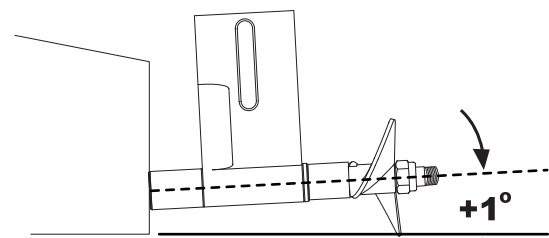
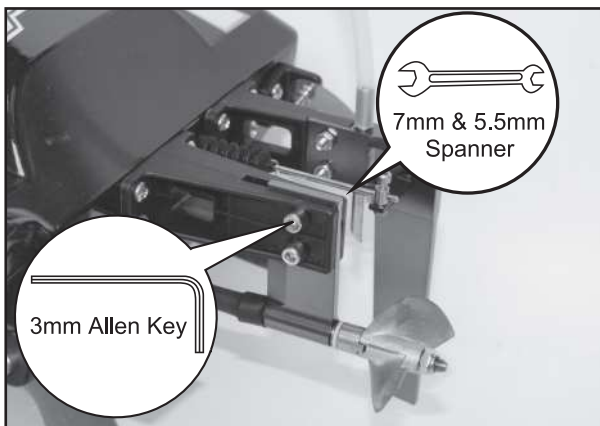

1) Above adjustment is suitable for racing on flat water surface

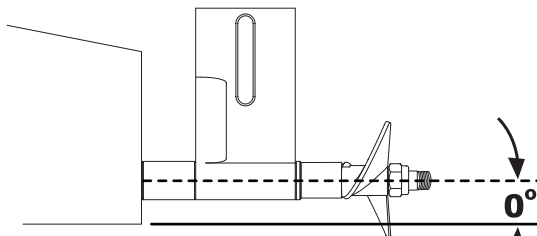

2) Above adjustment is suitable for racing on between light and medium wind and wave.

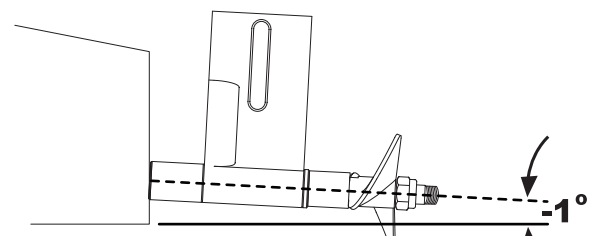

3) Above adjustment is suitable for racing on between medium and big wind and wave.

IMPORTANT NOTE:

1. It is not suitable to race boat in too strong wind and wave.
2. Model can achieve high speed, must slow down when steering.

Adjusting the rear strut to a higher position will increase top-end speed, but reduce steering response and could cause cavitation (unwanted vibration) if excessively adjusted, which can cause harm to the motor and ESC. It will also result in a decrease of top-end speed.

Adjusting the rear shaft down will increase steering response, but could cause the model to oversteer and reduce overall speed. This adjustment can be beneficial when running on rougher water however.

Generally, it is better to make small adjustments either way and see what effect this has on the operation of the model.

WATERPROOFING TIPS

You should take steps to ensure that your Alpha model and its radio control equipment are adequately protected against the possibility of water damage. Place your model's receiver inside the included rubber bag (balloon) and tie the end off with a cable tie or similar.

Ensure the propeller's flexible shaft is properly lubricated (see below) as this too will reduce the possibility of water entering the hull during operation.

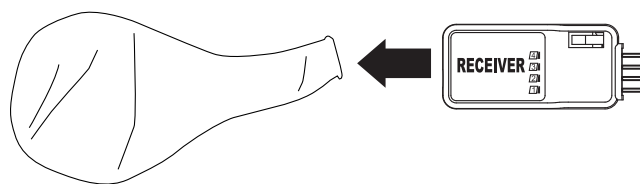

LUBRICATING THE PROPELLER SHAFT

Lubricating the Alpha model's flexible propeller shaft is vital to its smooth operation and lifespan. The lubricant also acts as a water seal, helping to prevent water from entering the hull via the propeller tube.

It is recommended that you lubricate the propeller shaft and tube every 2~3 hours of operation.

1) Used 2.0mm allen key to loose the set screw on motor coupler.

2) Next, remove the propeller nut, propeller and nylon washer.

The flexible shaft shroud can now be pulled off the end of the flexible shaft.

3) Lubricate the flexible shaft and shroud with waterproof marine grease and re-install. Re-installation is the reverse of the disassembly procedure.

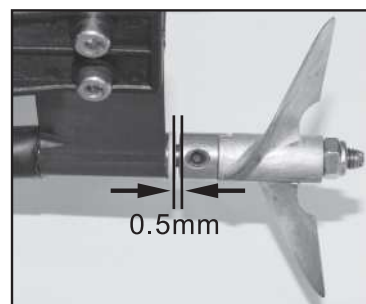
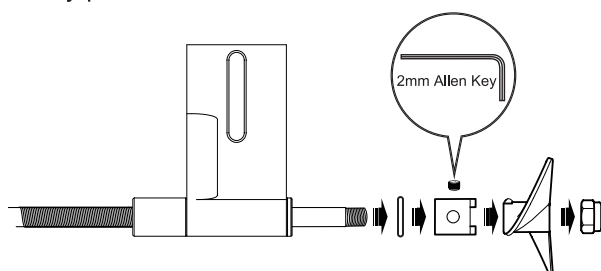

IMPORTANT NOTE:

It is very vital that leave 0.5mm gap between nylon washer and propeller support.

Neglect to do this will lead to overloaded.

INSTALLING BATTERY PACKS IN ALPHA MODEL

(Model should be placed on its supplied boat stand with the transmitter switched 'ON')

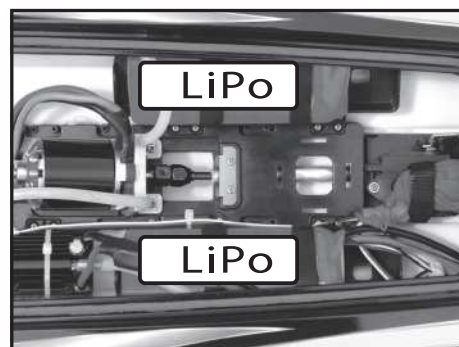
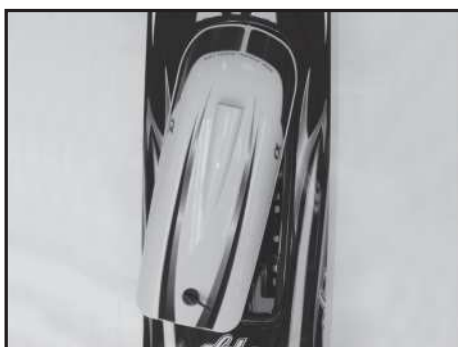

1) Remove the Alpha model's upper deck by rotate the plastic lock at its rear section.

2) Insert battery packs into the hull as shown below and secure with the hook and loop strap inside the hull.

3) Attach the battery pack's connectors to the matching connectors in the model. Do not force them together - they only attach one way!

4) Re-position the upper deck, securing with the plastic lock.

Attention: Before replacing the Alpha model's upper deck, check to ensure that the water-cooling tubing that connects to the motor is not obstructed or kinked, as this can cause the motor and speed controller to overheat and potentially burn out.

Note 1: Alpha models will typically run for around 4 minutes on fully charged Li-Po battery packs, although this will vary depending on the type and capacity of Li-Po packs you choose. As soon as you notice a drop off in speed you should bring the model back to shore or control may be lost.

Note 2: If you want to run your Alpha model for extended periods, you can purchase additional Li-Po battery packs. However, continuous running of the model will generate high heat levels which will lead to premature wear of the brushless motor. Once your Li-Po battery packs are exhausted, we recommend that you let the model cool down for 5~10 minutes before installing fresh ones.

TRIM TABS

Your Alpha model features an adjustable trim tab. Trim tabs allow the boat to operate at its optimum hull-to-water configuration and enable you to adjust the hull for best operation in differing conditions from flat calm to choppy water. It can also be used to adjust when the boat leans (lists) to one side when moving and act like an adjustable wing which allows the boat to get up on plane at slower speeds, which is more efficient.

To adjust the trim tab, you only need to turn in or turn out the adjusting screw (using the included Allen key) and lock off the setting by tightening the included nut. The more you screw in and extend the trim tab, the more the boat's bow (nose) will be pushed towards the water.

Note: Trim tabs are factory-set level with the bottom of the hull, or zero degrees. Adjustments should not be made no more than 3 degrees, or performance/control will be adversely affected. Make small adjustments at a time and see what effect this has on performance.

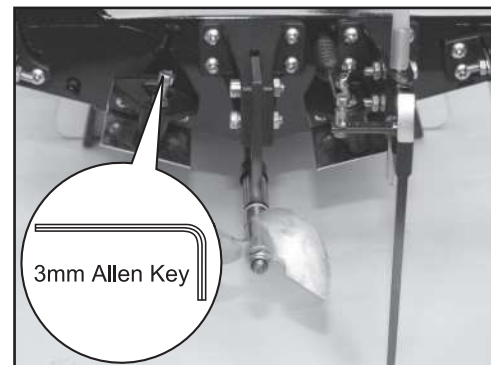

INSTALLING TRANSMITTER BATTERIES

NOTE: The transmitter is not water resistant and should never come in contact with water.

1. Install four fresh "AA" batteries. Follow the diagram located in the bottom of the battery tray for proper battery orientation.

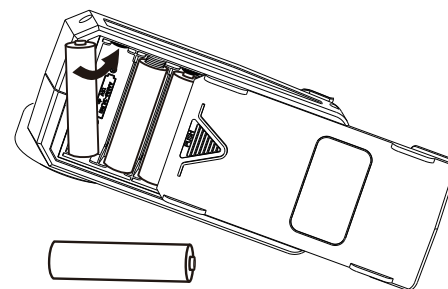

2. Turn the transmitter "ON". The battery light should glow bright RED.

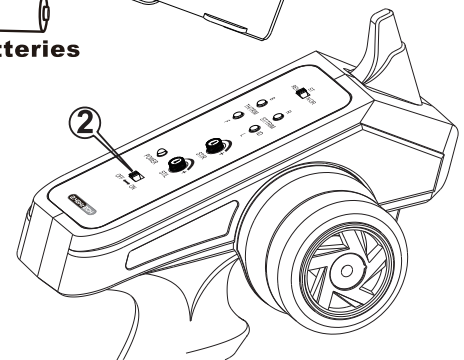

RECEIVER CONNECTION DIAGRAM

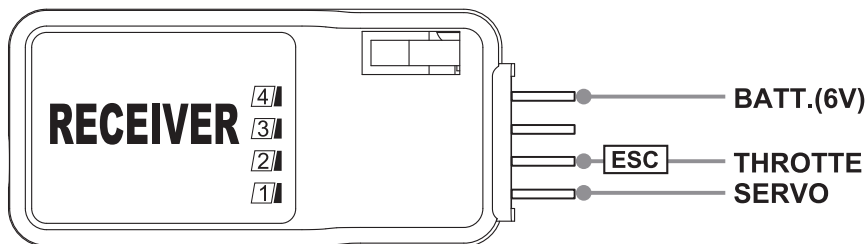

Note: If ESC with BEC function, no need to connect battery with receiver.

TRANSMITTER/RECEIVER BINDING

The binding process effectively ties the transmitter and receiver together. Under normal circumstances, both items are supplied like this from the factory. If, however, you find that your transmitter and receiver are not bound (receiver's red LED is on), you should do the following:

- 1) Switch "ON" the transmitter.
- 2) Switch "ON" the receiver by connecting battery to ESC, and ESC cord is plug into Receiver properly (Note: ESC has BEC function).
- 3) Press down the "BIND" button on the receiver, the receiver's green LED will be on to indicate that binding has been successful and the receiver will now accept commands from the transmitter.

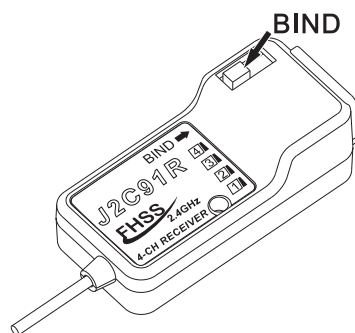

Note 1: During binding process, transmitter and receiver should be no more than one meter apart and no other similar devices should be within 10 meters.

Note 2: if the green light flashing, showing the binding failure, please do again as above indication.

GETTING READY TO USE YOUR ALPHA MODEL

(Model should be placed on its supplied boat stand)

Checking the radio system

1. Always turn the power "ON" to the transmitter before connecting the batteries with the ESC.

2. Plug the battery into the ESC plugs and listen for three continuous >Be<>Be<>Be< . (Signal noise of auto detected ESC)

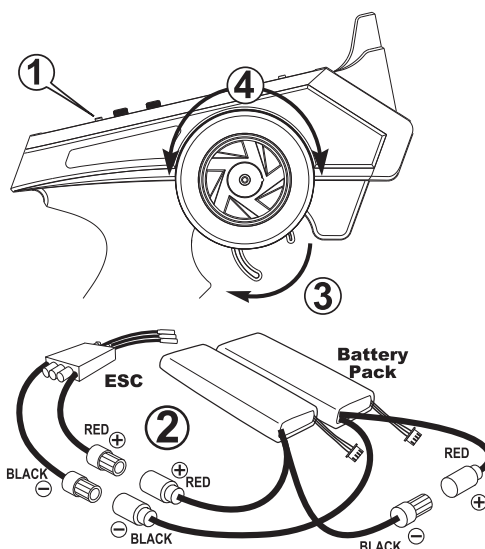

3. Pull the throttle & motor rotate in anticlockwise direction, your motor is now armed and ready for operation.

4. Check the direction of the rudder, the trailing edge of the rudder should turn right when right input is given. Conversely, when left input is given, the trailing edge of the rudder should turn left.

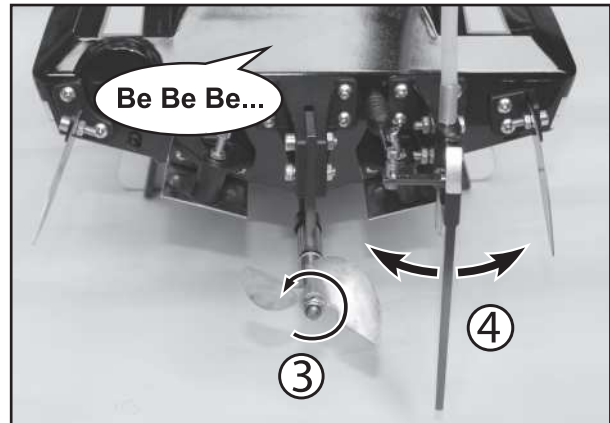

AFTER USE

- 1) When you have finished using your Alpha model, you should first switch 'OFF' the model (disconnect the Li-Po battery packs), then switch 'OFF' your transmitter.
- 2) Remove all batteries from the transmitter and model.
- 3) Leave the Alpha model's upper deck off to allow moisture to evaporate. Also, temporarily remove the receiver from its rubber bag. Ideally, place the model in this way in a warm and dry place, like an airing cupboard, until you are sure it is dry and then store it away.
- 4) Periodically grease the Alpha model's propeller shaft and tube as this will reduce wear and also help prevent water from entering the hull.

ESC (ELECTRONIC SPEED CONTROLLER) CALIBRATION & SPECIFICATION

NOTE: Please read separately supplied ESC instruction manual.

TRANSMITTER INTRODUCTION

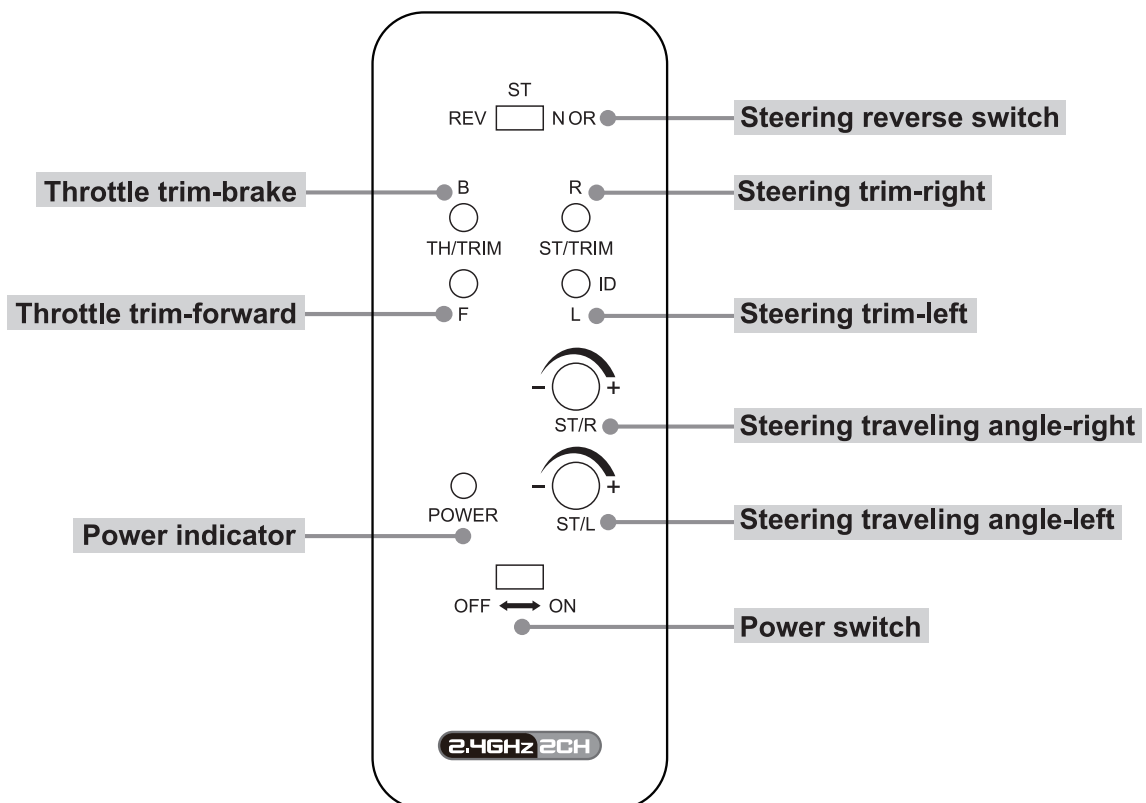

EPA ADJUSTMENT

Function

Use this when performing left and right steering angle adjustments. End Point Adjustment (EPA) adjusting value range: 0%-100%

Setting

1. Steering (right side) angle adjustment Rotate "ST/R" knob to the left end point means minimum value 0%, right end point means maximum value 100%.
2. Steering (left side) angle adjustment Rotate "ST/L" knob to the left end point means minimum value 0%, right end point means maximum value 100%.

CAUTION:

When adjusting this function, make sure the direction is in agreement with the boat direction, you can adjust by the STEERING "REV-NOR" button.

Steering reverse switch

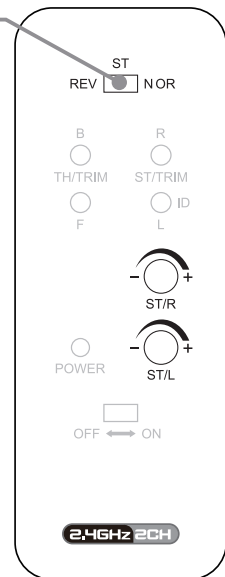
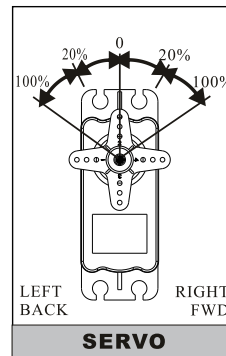

TRIM ADJUSTMENT

Steering trim

Adjust "ST/TRIM" "R/L" so that rudder is centered prior to operation, you may adjust this control to make the boat run straight during operation.

CAUTION:

When adjusting steering trim, make sure the direction is in agreement with the boat direction, you can adjust by the STEERING "REV-NOR" button.

Throttle trim

Adjust "TH/TRIM" "B/F" to stop propeller from turning while the throttle trigger is in the neutral position.

Steering reverse switch

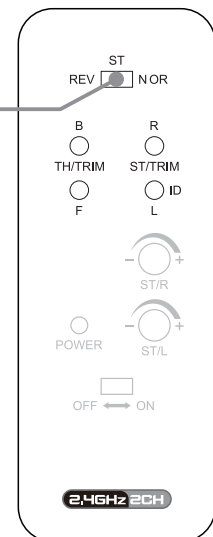

CIRCUIT & COOLING SYSTEM DIAGRAM FOR ALPHA BOAT

Each Alpha model is supplied from the factory with radio and cooling systems already set up. However, if you have cause to maintain, repair or replace parts in your model in the future, this chart can be of help when it comes time to re-installing/re-connecting everything.

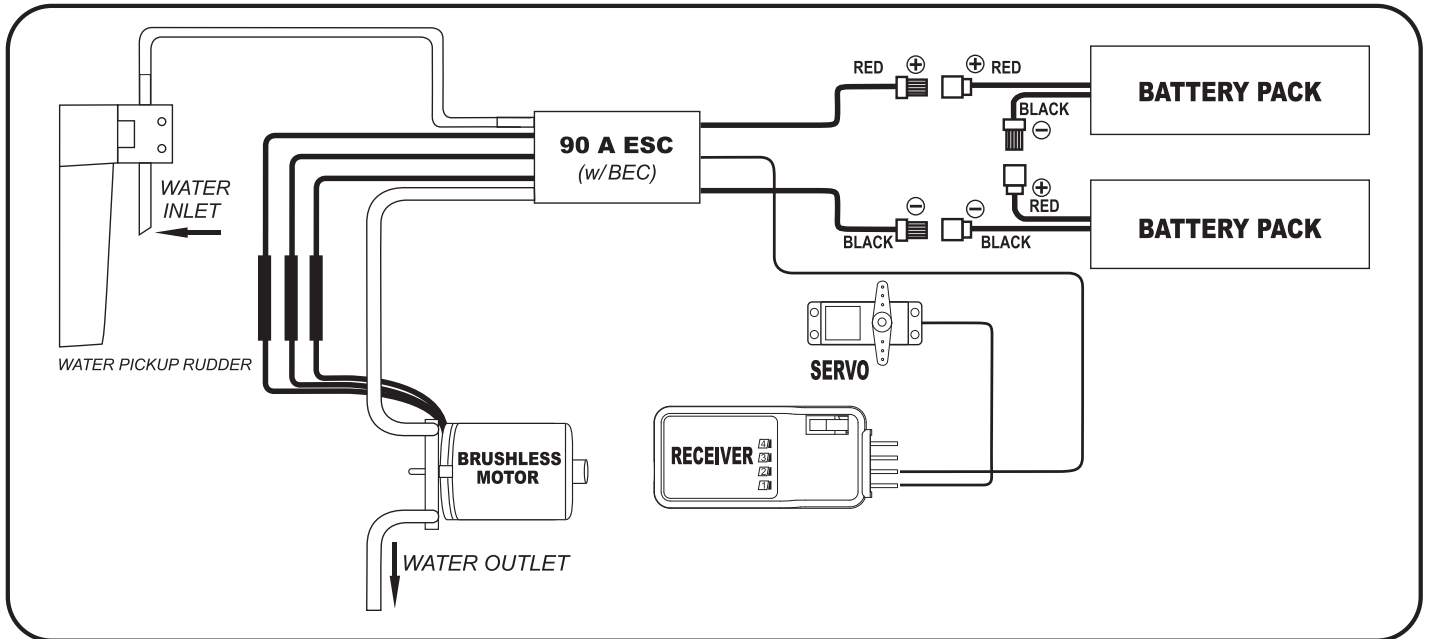

CAUTION!

Please observe the following warnings

DURING OPERATION

- Ensure that all batteries are correctly installed and that the Li-Po battery packs are fully charged.
- Do not touch moving parts during operation, especially the propeller.
- If you lose control of your Alpha model, never wade into deep water or water with strong currents to retrieve it. First, hold the transmitter as high as you can to try to re-establish control. If this does not work, find another way to move closer to the model, but do not endanger yourself in the process!

CARE WITH RECHARGEABLE BATTERIES (THE LI-PO BATTERY PACKS)

Care must be taken when handling rechargeable batteries (the Li-Po battery packs) to avoid the possibility of injury and/or damage to property. Do not short circuit, disassemble or incinerate rechargeable batteries. It is very dangerous to disregard these warnings.

GENERAL INFORMATION FOR THE SAFE OPERATION OF YOUR ALPHA MODEL

Please follow these simple rules to ensure safe operation and gain the maximum enjoyment from your model.

- This model is not a toy and should not be treated as such. Children under 14 years of age should not use this product unless closely supervised by an adult.
- Because this model is operated by radio control, it is important to ensure you always use fresh and/or fully charged batteries. Never allow the batteries to run low or you could lose control of the model!
- Never run your model in a public space where it might upset or endanger people or wildlife.
- Immediately switch 'OFF' your model and transmitter if you see lightning or hear thunder. Never use your model in the rain.

Do not dismantle or tamper in any way with this R/C vehicle and its transmitter. The manufacturer and distributor will accept no responsibility, expressed or implied, for accidents or injuries caused as a result of disassembly, modification and/or usage against the Instructions for this product.

Tampering or modification will also invalidate the guarantee.

TROUBLE SHOOTING

Check using the chart below before returning your Alpha model for repair as many problems can be easily solved.

PROBLEM	CAUSE	REMEDY
Model will not move	No batteries in transmitter/model Battery installation is incorrect Weak batteries in transmitter Weak batteries in model	Install batteries Install batteries correctly, checking polarity (+/-) Replace/recharge batteries Recharge Li-Po battery packs
No control of model	Weak batteries in transmitter	Replace/recharge batteries
Limited radio range	Weak batteries in transmitter	Replace/recharge batteries

SPARE PARTS LIST

Use belowing parts number in the parts list to order spare parts for Alpha boat.

890101	11.1V 5000mAh 40C LiPo pack
890102	7.4V 5000mAh 40C LiPo pack
890103	Red color hull only with decals and painting
890104	Yellow color hull only with decals and painting
890105	Red color hatch with decals and painting
890106	Yellow color hatch with decals and painting
890107	Water proof gasket(PK2)
890108	Out-runner brushless motor
890109	Water cooling motor mount set
890110	Motor coupler
890111	Flex shaft set
890112	Aluminum shaft tube
890113	CNC aluminum alloy rear shaft struct and plastic support set
890115	Bearing set(4 bearing+2 flange bearing)
890116	CNC aluminum alloy rudder with plastic rudder support set
890118	Back plate plastic mount for hardware installation
890119	Stainless steel turn fins and plastic stand set
890121	Stainless steel trim tabs and plastic stand set
890123	P1.4xD60mm two blade metal propeller (4S LiPo racing)
890124	P1.4xD56mm two blade metal propeller (6S LiPo racing)
890125	Water cooling silicone tube with spring
890126	Components plastic mount set(Motor/ESC/Servo/battery plastic mount)
890127	Connected rod of Rudder (with carbon tube)
890128	Display boat stand set with cushion
890129	Water cooling outlet set
890130	6mm gold plugs set for battery
92035	Water cooled 90A Brushless ESC W/ BEC
93017	water-proof rudder pushing rod tube(PK2)
950102	Water proof powerful 9kg high torque metal gear servo
930512	Velco strap set
880536	Rubber bung (PK4)
930518	J2C93 2.4GHz 2CH Transmitter
930519	J2C91R 2.4GHz 4CH Receiver

Upgrade metal parts list

890114	CNC aluminum alloy rear shaft struct and support set(Upgrade metal part)
890117	CNC aluminum alloy rudder and support set(Upgrade metal part)
890120	CNC aluminum alloy turn fins and stand set(Upgrade metal part)
890122	Stanless steel trim tabs and CNC aluminum alloy stand set(Upgrade metal part)



FCC REQUIREMENT



This device complies with Part 15 of the FCC Rules. Operation is subject to the following two conditions: (1) This device may not cause harmful interference, and (2) This device must accept any interference received, including interference that may cause undesired operation.

CAUTION: Changes or modifications to this product not expressly approved by the party responsible for compliance may void the user's authority to operate the equipment.